



PM 24VDC System

Section 02-01-08

Komatsu has made every effort to make this manual as accurate as possible based on the information available at the time of publication and printing. Continuous improvement and advancement of product design may cause changes to machines, which may not have been included in this publication. Komatsu reserves the right to make changes and improvements at any time. To ensure the most current information, please contact your service center.

Table of Contents

Scope of This Publication	3
Safety.....	3
Safety, Warnings and Cautions	4
Battery Maintenance	7
Safety in Battery Maintenance	7
Batteries	8
Checking Electrolyte Levels	9
Checking Specific Gravity.....	9
Cleaning.....	10
Recharging	10
Replacing Batteries.....	11
Battery Maintenance during Machine Storage	12
Battery Charging Alternator.....	13
Maintenance	13
Emergency Jump Starting.....	15
Low Voltage Control Cabinet.....	17
Emergency Shutdown Switch (E-Stop) Testing Procedure.....	21
Safety Preparations	21
Testing Procedure.....	23
Typical Graphic Symbols for Electrical Diagrams.....	29

List of Figures

Figure 1. Battery box location	8
Figure 2. Isolation and control switches assembly.....	9
Figure 3. Battery box –side view	11
Figure 4. Battery box	11
Figure 5. Isolation and control switches assembly box - fuse location	12
Figure 6. 24 VDC alternator	14
Figure 7. Jump start connection located inside switch box assembly (current production machines)	15
Figure 8. Low voltage control cabinet (left side)	17
Figure 9. Low voltage control cabinet (right side)	17
Figure 10. Axel access	18
Figure 11. Low voltage control cabinet	19
Figure 12. Electrical converter cabinet (typical).....	19
Figure 13. Low voltage control cabinet with e-stop card (Card not present on current production machines or machines with an upgraded E-stop system).....	21
Figure 14. Frame Lock.....	22
Figure 15. Isolation and Control Switch Assembly.....	22

Figure 16. Hydraulic reservoir air release valve..... 27
Figure 17. Starter isolation switch 28

Scope of This Publication

ELECTRICAL SYSTEM PREVENTIVE MAINTENANCE contains general and specific information for basic preventive maintenance of the electrical system of the machine. Only trained and experienced personnel should be allowed to inspect and service the machine.

Safety

This publication contains special instructions that pertain to safety, operation, maintenance, and repair of the machine. Listed below are the signal words and symbols that precede these instructions and their meanings:

DANGER

- The danger label indicates a hazardous situation which, if not avoided, will result in death or serious injury.

WARNING

- The warning label indicates a hazardous situation which, if not avoided, could result in death or serious injury.

CAUTION

- The caution label, used with the safety alert symbol indicates a hazardous situation which, if not avoided, could result in minor or moderate injury (includes the safety alert symbol ).

CAUTION

- The caution label (without safety alert symbol) is used to address practices not related to personal injury – only equipment damage.

NOTICE

The NOTICE graphic is to indicate areas of importance to the reader that are not related to personal injury or machine damage.

Safety, Warnings and Cautions

It is important that all personnel read and understand all CAUTIONS and WARNINGS before operating, or working on or near the machine.

WARNING

EYE INJURY, CHEMICAL BURNS, AND INGESTION HAZARDS

- Eye injury, chemical burns, and ingestion hazard exists when working with batteries. Always wear personal protective equipment when working with batteries. The batteries contain acid that is dangerous to contact, ingest, or to get into the eyes. Failure to wear PPE could cause eye injury, chemical burns or ingestion resulting in serious injury.

FIRE OR ELECTRICAL HAZARD

- Fire or electrical hazard exists if there is a buildup of combustible dust in any electrical compartment. A buildup of combustible dust can result in a fire hazard. It is critically important to remove any accumulation of combustible dust as part of the electrical system preventive maintenance program. Failure to keep electrical compartments clear of dust buildup can cause a fire hazard resulting in serious injury or death.

CRUSH HAZARD

- Crush hazard exists if a buildup of dust or dirt results in component failure. Keep all electrical connections and components clear of dust buildup. In extreme circumstances, unplanned movement of the machine could occur. Should unplanned movement of the machine occur upon starting the machine, IMMEDIATELY press the emergency stop button. Failure to keep all electrical connections and components clear of dust buildup can cause crush hazards resulting in serious injury or death.
- Crush hazards exist if the machine is started or moved while work processes are being performed on the machine. Place bucket flat and level on the ground. Place frame lock in the locked position and lock out the machine's starting capability before performing any work process. Follow all applicable lockout procedures and local rules and regulations for performing work processes. ANYONE performing inspections or service procedures to the machine should be familiar with ALL instructions and procedures contained in the machine's SERVICE MANUAL. Crush hazard could occur if the machine is started or moves while any type of work process is being conducted on the machine, resulting in serious injury or death.
- Crush hazards exist in machine pivot area and area between the tires. Do not enter these areas unless it is verified that the operator has control over the steering and that personnel locking the frame lock have good communication with the operator. Entering the pivot area and area between the tires while the machine is moving or pivoting (articulating) could cause crush hazards resulting in serious injury or death.

ENTANGLEMENT HAZARD

- Entanglement hazard exist if cranking the engine without the alternator guard in place. Never crank the engine without the alternator guard in place. Failure to have the alternator guard in place when cranking the engine can cause an entanglement hazard resulting in serious injury.

LEAD PRESENCE HAZARD

- Battery posts, terminals and related accessories contain lead and lead compounds, chemicals known to the State of California, USA to cause cancer and birth defects or other reproductive harm. Do not handle battery posts, terminals or related accessories containing let or lead compounds without wearing proper personal protective equipment (PPE) as required by local rules, regulations, or policies.

BURN HAZARD

- Burn hazard exists if jumper cables are connected improperly. Arcing can occur. Burns are possible. Komatsu recommends that the machine only be jump started with the jump start connection. Refer to illustration “Jump start connection located inside switch box assembly”. Failure to connect jumper cables correctly can cause burn hazards resulting in serious injury.

EXPLOSION HAZARD

- Explosion hazard exists by gas given off by the battery. Be careful not to create sparks that could cause an explosion. NEVER check the battery charge by placing a metal object across the posts. NEVER smoke while examining battery electrolyte levels. NEVER use an open flame to check battery electrolyte levels. Use a flashlight. Failure to prevent sparking around the battery can cause an explosion hazard resulting in serious injury.

CAUTION

EYE INJURY AND BURN HAZARDS

- Eye injury and burn hazard exists because battery electrolyte is an acid and can cause blindness if it contacts the eyes and it can cause chemical burns if it contacts the skin. **WEAR SAFETY GOGGLES AND FACESHIELD FOR EYE PROTECTION WHEN WORKING WITH A BATTERY.** Wear all other locally required personal protective equipment (PPE) when working with a battery. Failure to use personal protective equipment (PPE) can cause eye injury or skin burns resulting in serious injury.

EYE INJURY HAZARD

- Eye injury hazard exists when cleaning electrical cabinets. Flying debris can injure the eye if appropriate personal protective equipment (PPE) is not worn. Always wear the appropriate PPE when cleaning electrical cabinets. Follow local rules for performing electrical work. A vacuum hose is recommended. Compressed air is not recommended for cleaning components. Failure to wear PPE can cause various injuries including eye injury resulting in serious injury.

This Page Intentionally Left Blank

Battery Maintenance

The following general recommendations for the maintenance of the batteries on the machine will increase productivity and reduce downtime. Both operators and maintenance personnel should pay close attention to these guidelines and to the safety precautions in these instructions.

NOTICE

All local procedures and all appropriate rules and regulations shall be used when working with chemicals such as battery acid. Follow all appropriate lawful procedures/rules/regulations (not covered in this document) to contain and when using, disposing of, or working with battery acid. Contact the manufacturer for MSDS sheets for chemicals. Always contain all chemicals as applicable.

WARNING

Eye injury, chemical burns, and ingestion hazard exists when working with batteries. Always wear personal protective equipment when working with batteries. The batteries contain acid that is dangerous to contact, ingest, or to get into the eyes. Failure to wear PPE could cause eye injury, chemical burns or ingestion resulting in serious injury.

Safety in Battery Maintenance

WARNING



Explosion hazard exists by gas given off by the battery. Be careful not to create sparks that could cause an explosion. NEVER check the battery charge by placing a metal object across the posts. NEVER smoke while examining battery electrolyte levels. NEVER use an open flame to check battery electrolyte levels. Use a flashlight. Failure to prevent sparking around the battery can cause an explosion hazard resulting in serious injury.

CAUTION

Eye injury and burn hazard exists because battery electrolyte is an acid and can cause blindness if it contacts the eyes and it can cause chemical burns if it contacts the skin. WEAR SAFETY GOGGLES AND FACESHIELD FOR EYE PROTECTION WHEN WORKING WITH A BATTERY. Wear all other locally required personal protective equipment (PPE) when working with a battery. Failure to use personal protective equipment (PPE) can cause eye injury or skin burns resulting in serious injury.

WARNING

Battery posts, terminals and related accessories contain lead and lead compounds, chemicals known to the State of California, USA to cause cancer and birth defects or other reproductive harm. Do not handle battery posts, terminals or related accessories containing lead or lead compounds without wearing proper personal protective equipment (PPE) as required by local rules, regulations, or policies.

- a. Battery acid (sulfuric acid) is harmful to skin and to most materials. Immediately remove any clothing on which acid is spilled.
- b. If acid contacts the skin, rinse the affected area 10 to 15 minutes with running water.
- c. If acid splashes into the eyes, flush with running water 10 to 15 minutes. Be sure to force the eyelids open while flushing with water. The victim should be taken IMMEDIATELY to a doctor for further treatment.
- d. Acid spilled on the floor or on paint or metal surfaces of a machine can be neutralized by using a mixture of one pound of baking soda to one gallon of water or one pint of household ammonia to one gallon of water.

Perform the following servicing procedures in conjunction with the MODULAR PM SCHEDULES (POST BREAK-IN PERIOD), located in Section 02 of the Service Manual.

Batteries

The machine's batteries are mounted in protective boxes, located on the right side of the tow unit at the rear. Refer to illustration "Battery box location".



Figure 1. Battery box location

CAUTION

Use the "Battery Disconnect Switch" to isolate the solid-state electronics of the machine and the engine before charging or replacing the machine batteries. Serious damage to these components is possible from reversed polarity or arcing. Refer to illustrations "ISOLATION AND CONTROL SWITCHES ASSEMBLY".

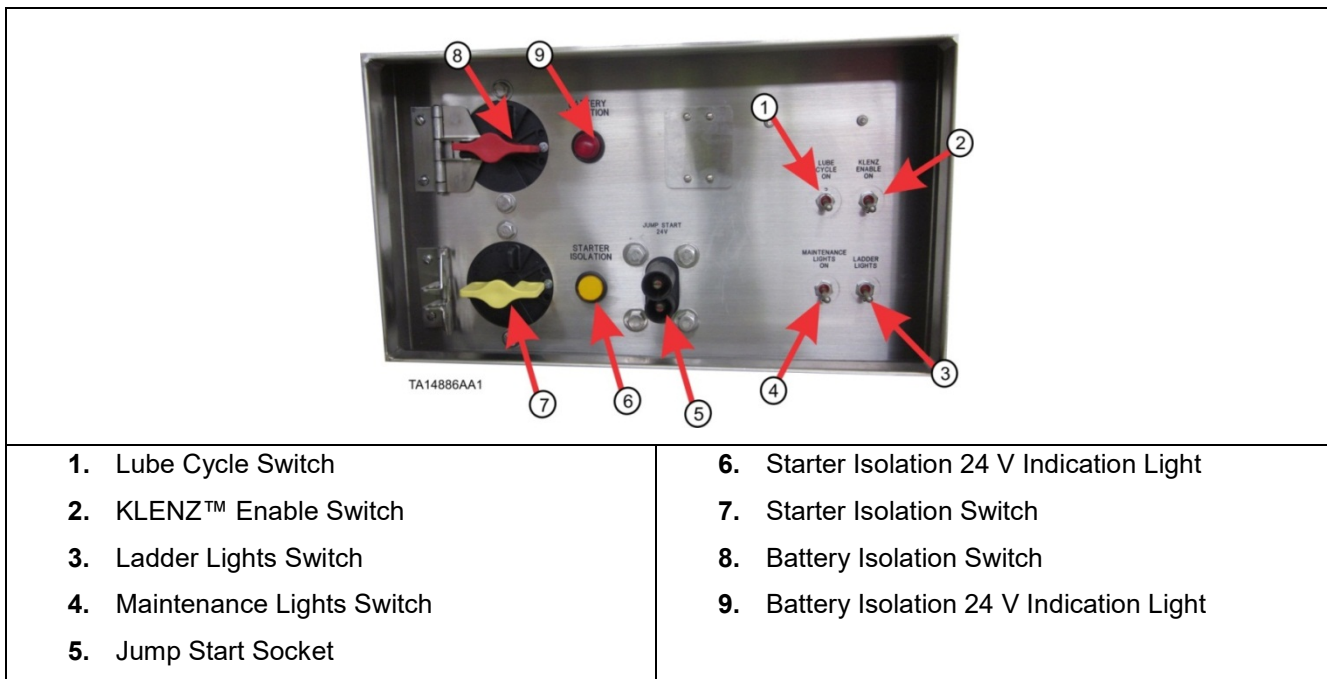

Figure 2. Isolation and control switches assembly

Checking Electrolyte Levels

- Check electrolyte level weekly, or as recommended by battery manufacturer. Also inspect vent holes in caps to be sure they are open. Electrolyte level should be at the bottom of the filler necks and above the tops of the battery plates.
- Use distilled water to bring electrolyte to proper level. Do not use tap or surface water; dissolved minerals will leave deposits on the plates that will interfere with chemical action.
- Do not overfill. Excess electrolyte will escape through the vent holes and leave deposits on the tops of the batteries.
- Add only distilled water unless electrolyte has been lost by spilling.
- If water must be added to a battery in freezing weather, immediately run the engine long enough to assure proper mixing.

Checking Specific Gravity

Before adding water, use a hydrometer to check the specific gravity of the electrolyte. It should be between 1.215 and 1.270 when electrolyte temperature is 80° F (26.6° C). If the hydrometer does not have a temperature correction scale, add four gravity points (0.004) for each 10° above 80°, and subtract four points for each 10° under 80°. Battery cells that differ more than 50 specific gravity points indicate an unsatisfactory battery condition caused by an internal defect, short circuit, or deterioration from extended use. The battery should be replaced.

Cleaning

- a. Clean batteries every 250 hours, more often if there are heavy sulfate deposits on the case and terminals.
- b. Remove the terminals carefully; never pry against the battery case. Clean the terminals both inside and out, and dip them in a solution of four tablespoons of baking soda to one pint of water.
- c. Clean the posts and the top of the battery and brush on a fresh mixture of baking soda and water. Apply this solution until foaming stops, then flush with clean water, making sure neither the solution nor flushing water enters vents in the caps (the electrolyte could be neutralized or contaminated). Dry the battery and posts with a clean cloth.
- d. After replacing the cable terminals, apply a coating of petroleum jelly or light grease to the terminal clamps to protect from corrosion.
- e. Be sure each terminal is on the proper post (+) positive, (-) negative or the alternator may be damaged. Do not use a hammer to force the clamps into place.

Recharging

- a. Cell caps should be removed when charging batteries. Follow the charger manufacturer's instructions.
- b. Badly sulfated batteries (acid deteriorated plates) will not accept fast charging without the danger of damage; they must be recharged slowly. The normal slow-charging period is 12 to 24 hours, but badly sulfated batteries may require 60 to 100 hours for complete recharge.
- c. NEVER charge a frozen battery; it could explode. Warm to 60° F (15.5° C) before charging.

NOTICE

In extremely cold climates where freezing of battery electrolyte is a problem, battery heaters are recommended.

- d. When using an external source to charge the machine's batteries, turn off the battery isolator switch or battery disconnect switch (as applicable) before attaching the cables - refer to illustration "ISOLATION AND CONTROL SWITCHES ASSEMBLY" as applicable.

Replacing Batteries

- a. Troubleshoot the battery before you replace it; many batteries that are replaced may not be faulty and may just be completely discharged.
- b. Choose a replacement battery with an ampere-hour rating at least equal to the original.



(Right side at rear of machine)
 (Hand rail will vary between models)

Figure 3. Battery box –side view



Battery positions may vary

Figure 4. Battery box

NOTICE

The battery fuses are located in the Isolation and Control Switches Assembly Box, located on the left rear of the machine.

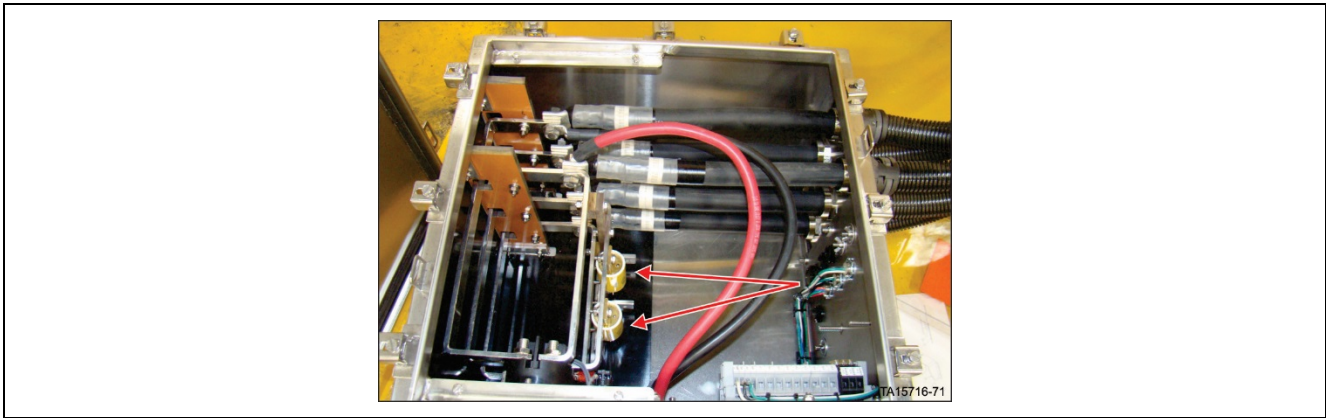

Figure 5. Isolation and control switches assembly box - fuse location

WARNING

Electrical burn hazard exists with working in the ISOLATION AND CONTROL SWITCHES ASSEMBLY BOX. Always disconnect battery cables in the battery box to prevent electrical shorts, flash arcs or equipment damage. Failure to disconnect battery cables could cause electrical burns and component damage result in serious personal injury.

Battery Maintenance during Machine Storage

The following recommendations should be followed for maintenance of the batteries during storage of the machine:

30 days or less: Where moderate temperatures are expected, the batteries may be left in the machine. If the machine is not going to be used for approximately 30 days, the batteries may need a boost at the end of the storage period.

30 days or less - extreme temperatures - hot/cold: It is recommended the batteries be removed and taken into a shop where they can be inspected, brought up to full charge, and placed on a trickle charger to keep them at full charge.

Extended storage: The batteries should be removed from the machine and stored in a suitable place where they are protected from extremes of heat and cold and charged at least every 30 days or kept on a trickle charger.

Battery Charging Alternator

The alternator is either a 24 VDC, 140-amp or 270-amp (machine dependent), brushless model. The alternator is mounted on the front side of the engine. The alternator is driven by the engine's alternator drive via a drive belt. The alternator's charge rate is monitored by the LINCS® computer system. If a problem is detected by the computer, the appropriate alarm or warning message, red or amber light and audible alarm will alert the operator to the problem. A guard covers the alternator pulley, drive belt, and alternator drive pulley. Refer to illustration "24 VDC alternator".

Maintenance

Check the alternator and metal guard mounting bolts and electrical connections for tightness, monthly or every 100 hours. The alternator itself requires no maintenance.

The alternator drive belt should be inspected at the same interval for cracks, rib material broken away, overheating, and wear. The drive belt can be quickly inspected by looking at the belt from the backside of the metal guard. Should a closer inspection be required, remove the metal guard.

NOTICE

Normal wear would have one or two cracks in the ribs around the entire circumference of the belt. Cracks usually appear after long-term use. If only normal wear is evident, the belt can continue to be used. The belt must be replaced if the ribs are broken around the entire circumference or any rib material has broken off.

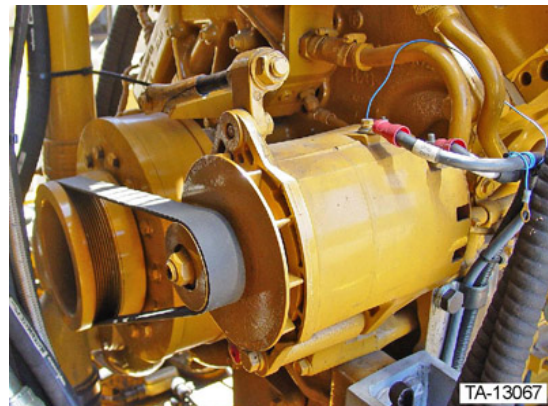

Typical installation

NOTICE

Belt guard has been removed for clarity of illustration.

WARNING

Entanglement hazard exist if cranking the engine without the alternator guard in place. Never crank the engine without the alternator guard in place. Failure to have the alternator guard in place when cranking the engine can cause an entanglement hazard resulting in serious injury.



1) Alternator
(Mounted front of engine)

Figure 6. 24 VDC alternator

Emergency Jump Starting

WARNING

Burn hazard exists if jumper cables are connected improperly. Arcing can occur. Burns are possible. Komatsu recommends that the machine only be jump started with the jump start connection. Refer to illustration “Jump start connection located inside switch box assembly”. Failure to connect jumper cables correctly can cause burn hazards resulting in serious injury.

CAUTION

Equipment damage is possible if jumper cables are connected improperly. Arcing can occur. It is possible to damage the electronic controls of the machine and engine. Komatsu recommends that the machine only be jump started with the jump start connection. Refer to illustration “Jump start connection located inside switch box assembly”. Failure to connect jumper cables correctly can cause equipment damage.

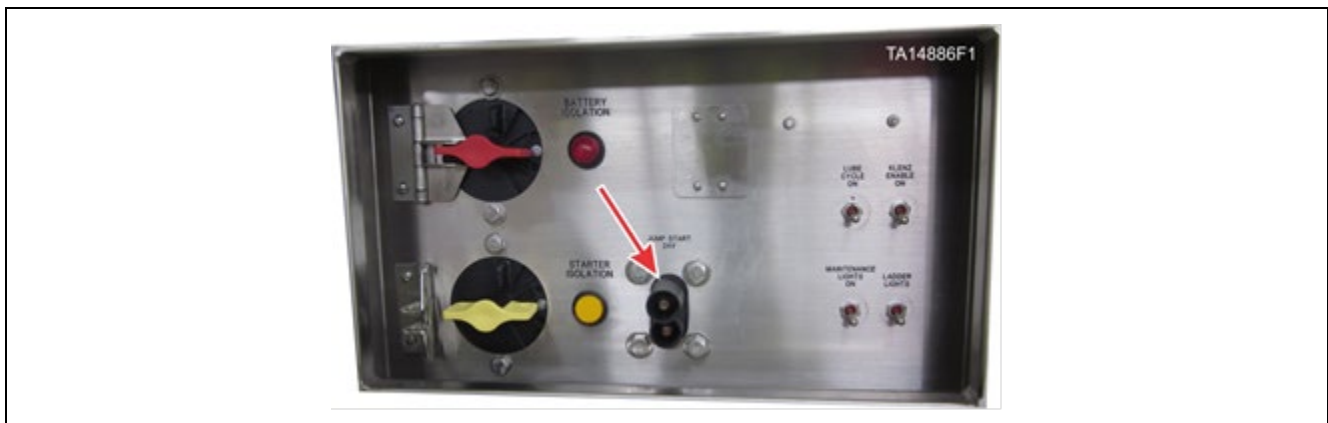

Figure 7. Jump start connection located inside switch box assembly (current production machines)

This Page Intentionally Left Blank

Low Voltage Control Cabinet

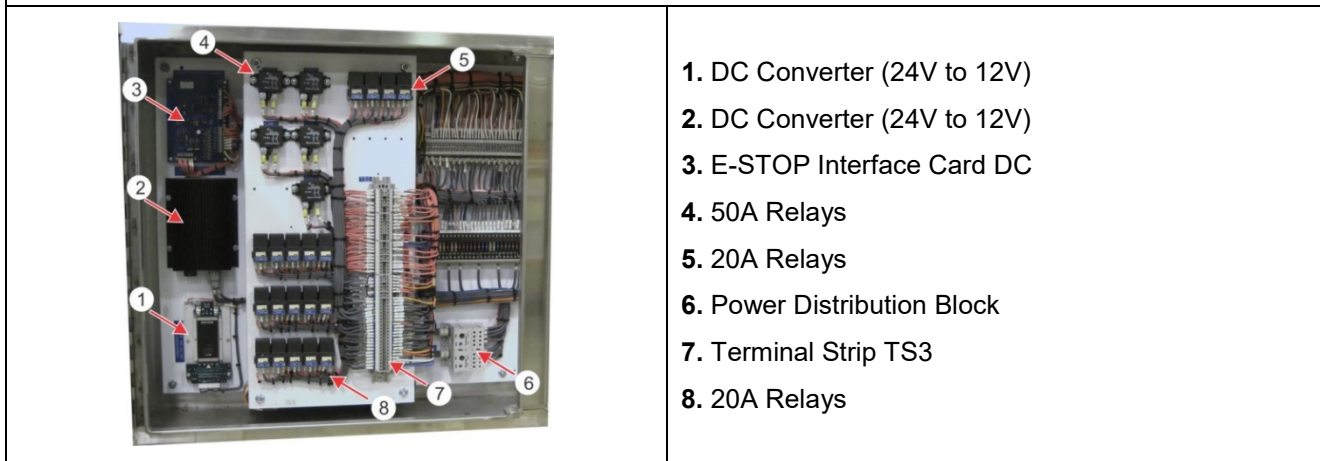

Figure 8. Low voltage control cabinet (left side)

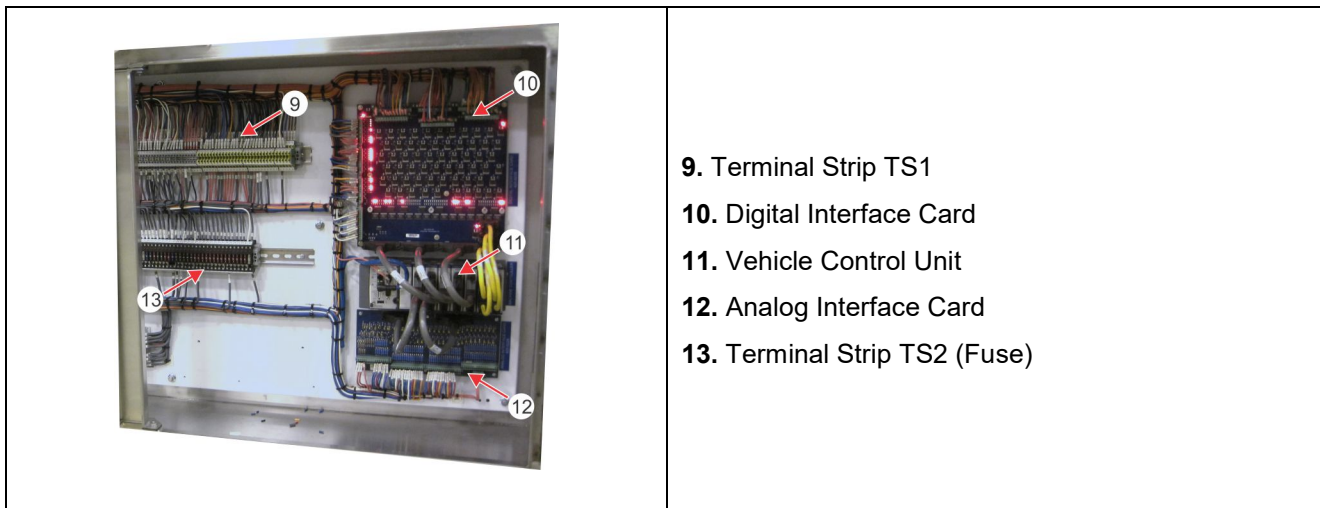
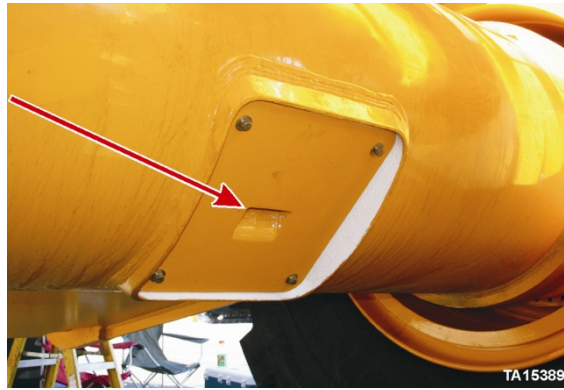

Figure 9. Low voltage control cabinet (right side)



**Axle (similar access in rear axle)
Safety labels not shown**

Figure 10. Axel access

As part of the 500 hour electrical system preventive maintenance program, it is recommended that the high voltage electrical cabinet, low voltage cabinet and inside the axles be cleaned out with clean dry compressed air or a powerful vacuum cleaner. Machines used in extremely dusty conditions may require more frequent inspections and cleaning.

CAUTION

Eye injury hazard exists when cleaning electrical cabinets. Flying debris can injure the eye if appropriate personal protective equipment (PPE) is not worn. Always wear the appropriate PPE when cleaning electrical cabinets. Follow local rules for performing electrical work. A vacuum hose is recommended. Compressed air is not recommended for cleaning components. Failure to wear PPE can cause various injuries including eye injury resulting in serious injury.

WARNING

Crush hazard exists if a buildup of dust or dirt results in component failure. Keep all electrical connections and components clear of dust buildup. In extreme circumstances, unplanned movement of the machine could occur. Should unplanned movement of the machine occur upon starting the machine, IMMEDIATELY press the emergency stop button. Failure to keep all electrical connections and components clear of dust buildup can cause crush hazards resulting in serious injury or death.

WARNING

Fire or electrical hazard exists if there is a buildup of combustible dust in any electrical compartment. A buildup of combustible dust can result in a fire hazard. It is critically important to remove any accumulation of combustible dust as part of the electrical system preventive maintenance program. Failure to keep electrical compartments clear of dust buildup can cause a fire hazard resulting in serious injury or death.

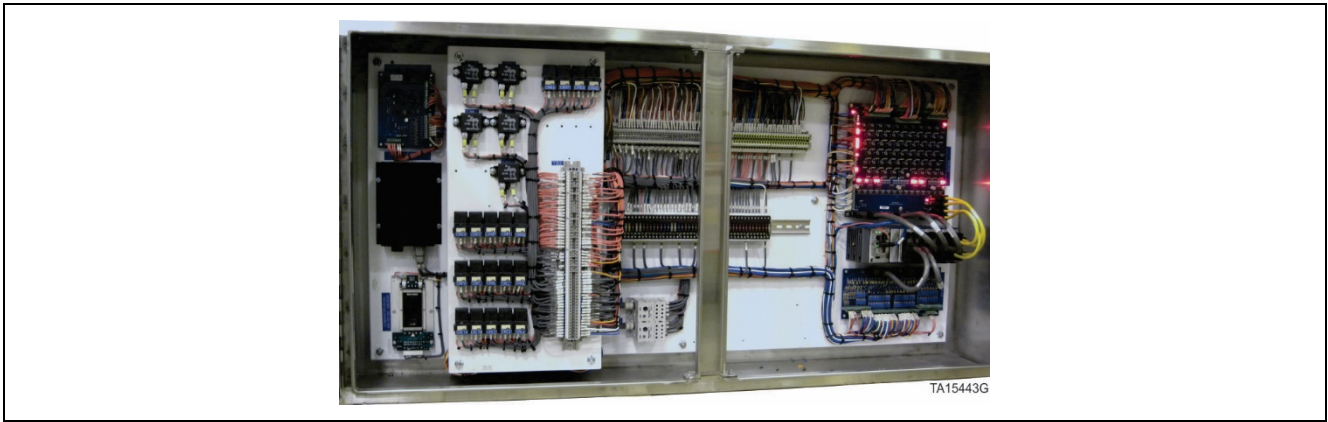

Figure 11. Low voltage control cabinet



Figure 12. Electrical converter cabinet (typical)

This Page Intentionally Left Blank

Emergency Shutdown Switch (E-Stop) Testing Procedure

NOTICE

The following procedure is only valid for current production machines (or machines with an upgraded E-stop system). The procedure cannot be used on early production machines that still have an E-stop card inside the Low Voltage Control Cabinet (LVCC). Use the pictures below to determine if this procedure is valid for the system to be tested.

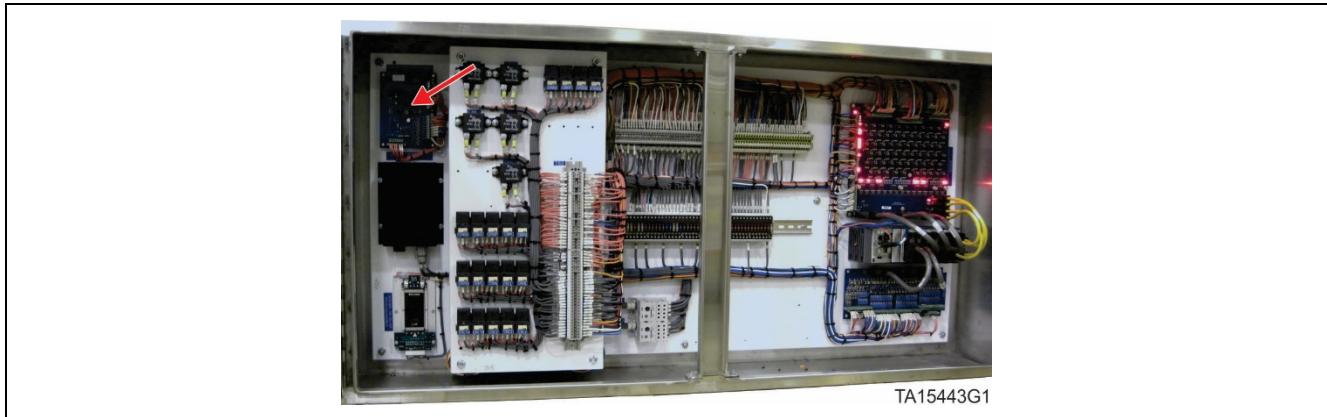

Figure 13. Low voltage control cabinet with e-stop card (Card not present on current production machines or machines with an upgraded E-stop system).

Safety Preparations

WARNING

Crush hazards exist if the machine is started or moved while work processes are being performed on the machine. Place bucket flat and level on the ground. Place frame lock in the locked position and lock out the machine's starting capability before performing any work process. Follow all applicable lockout procedures and local rules and regulations for performing work processes. ANYONE performing inspections or service procedures to the machine should be familiar with ALL instructions and procedures contained in the machine's SERVICE MANUAL. Crush hazard could occur if the machine is started or moves while any type of work process is being conducted on the machine, resulting in serious injury or death.

- a. Stop the wheel loader on flat level ground.
- b. Move the frame lock to the locked position so that the frame cannot be steered.

WARNING

Crush hazards exist in machine pivot area and area between the tires. Do not enter these areas unless it is verified that the operator has control over the steering and that personnel locking the frame lock have good communication with the operator. Entering the pivot area and area between the tires while the machine is moving or pivoting (articulating) could cause crush hazards resulting in serious injury or death.

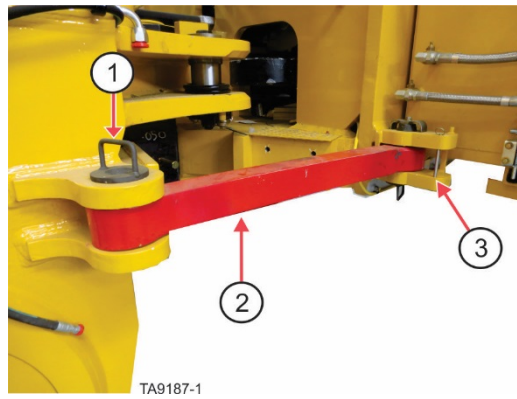

1) Retaining pin for locked position, 2) Frame lock - shown in locked position,
3) Retaining pin bracket for un-locked position

Figure 14. Frame Lock

- c. Place wheel chocks in front and behind each wheel.
- d. Set bucket flat and level on the ground.
- e. Set the parking brakes.
- f. At the battery box, isolate the starter, making the machine unable to start.

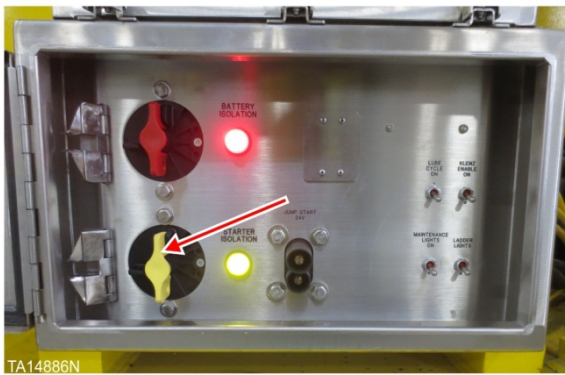

Isolate and lockout the starter

Figure 15. Isolation and Control Switch Assembly



Testing Procedure

Before beginning the procedure, make sure the key switch is turned ON and the LINCOS system is completely booted up. The engine should not be running.

NOTICE

The following E-Stop test procedure describes taking voltage measurements and placing jumpers on relay terminals. In some instances it may be easier to take voltage readings or place jumpers on the appropriate wire terminal blocks. Please consult your machines schematic to ensure that all measurements and jumpers are taken or placed at the correct location.

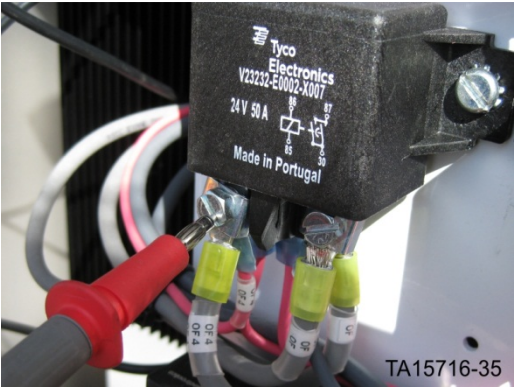
1. Press and reset the cab E-stop to verify proper operation of relays in the Low Voltage Control Cabinet (LVCC).
 - a. 0F4 (CRES1-87) has 0V when the E-stop is pressed and 24V when the E-stop is reset.
 - b. Remove CRES4 from its socket.
 - c. 0F2 (CRES3-87) has 0V when the E-stop is pressed and 24V when the E-stop is reset.
 - d. 0F3 (CRES3-87a) has 24V when an E-stop is pressed and 0V when the E-stop is reset.
 - e. Replace CRES4 in its socket.

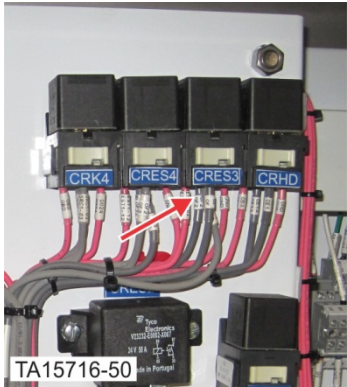
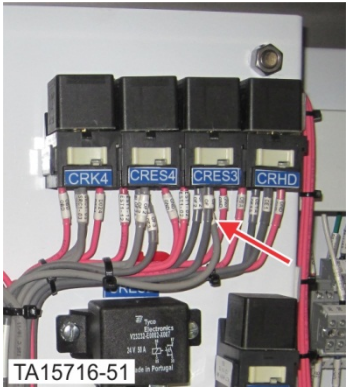
 <p style="text-align: right; font-size: small;">TA15716-35</p>	 <p style="text-align: right; font-size: small;">TA15716-36</p>
<p>a. Measuring Voltage at 0F4</p>	<p>b. Removing CRES4</p>
 <p style="text-align: right; font-size: small;">TA15716-50</p>	 <p style="text-align: right; font-size: small;">TA15716-51</p>
<p>c. CRES3-87 (0F2)</p>	<p>d. CRES3-87a (0F3)</p>

2. Repeat step 1. for each of the four ground level E-stops.

3. Press and reset the right rear E-stop to verify proper operation of relays in the Engine box.
 - a. DDEC (MTU)
 - i. Place a jumper from 2B (CR211-30) to 2BA (CR211-87). This jumper can also be applied at the appropriate terminal block.
 - ii. D439 (CR215-87) has 0V when the E-stop is pressed and 24V when reset.
 - iii. Remove the jumper at CR211.

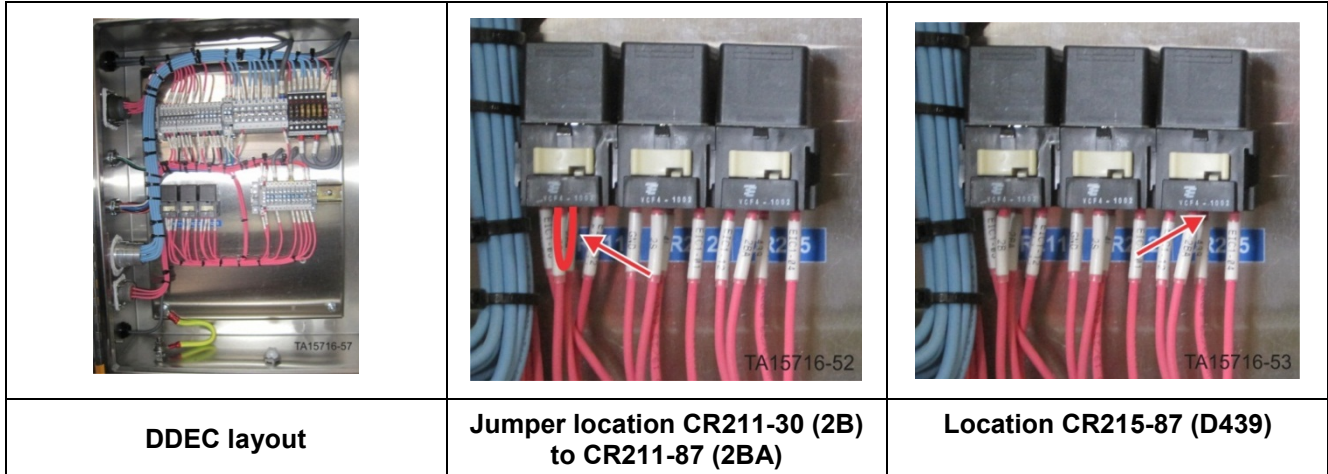

- b. ADEC (MTU)
 - i. Place a jumper from 2AA1 (CR213-30) to 2AA (CR213-87). This jumper can also be applied at the appropriate terminal block.
 - ii. 2AAA (CR215-30) has 0V when the E-stop is pressed and 24V when reset.
 - iii. Remove jumper at CR213.

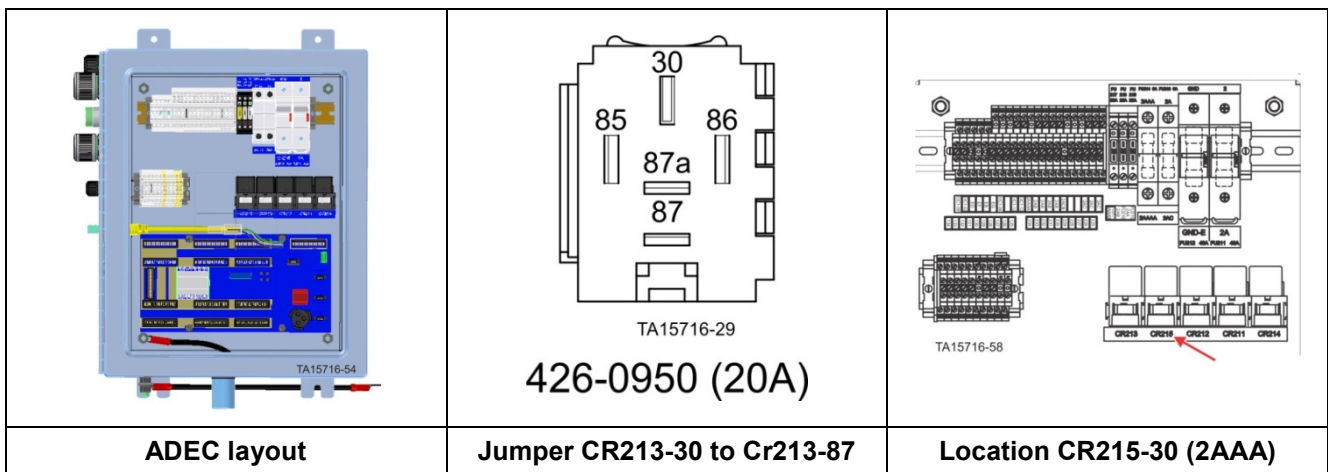

- c. Cummins
 - i. Place a jumper from Terminal Block F01 to Terminal Block F01A.
 - ii. Measure voltage at R01, 0V when the E-stop is pressed and 24V when reset.
 - iii. Remove the jumper from Terminal Block.

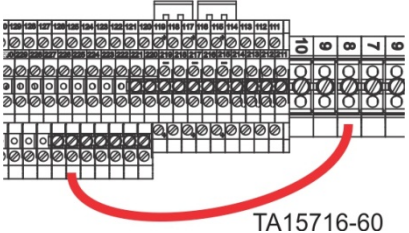
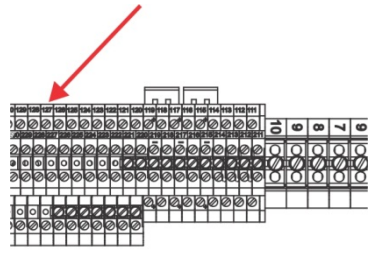
		
<p>Cummins layout</p>	<p>Jumper Location F01 to F01A</p>	<p>Location R01</p>

4. In the LVCC:

- a. Place a jumper from 0F (CRES1-30) to 0F4 (CRES1-87).
- b. Place a jumper from 0F (CRES3-30) to 0F2 (CRES3-87). This jumper can also be applied at the appropriate terminal block.
- c. Disconnect wire 0F3 from CRES3-87a and protect the loose wire from shorting out.

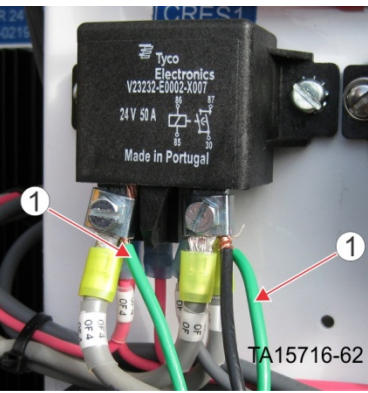
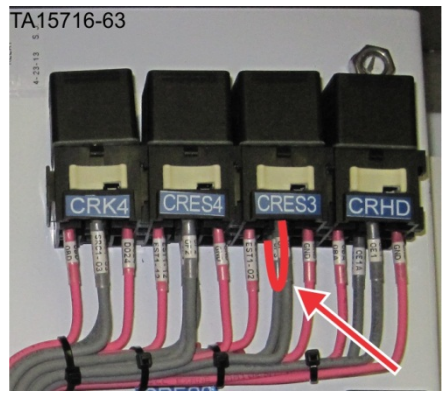
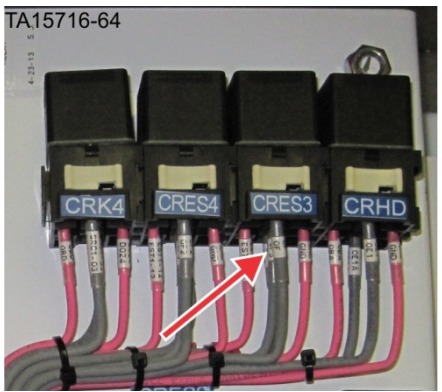
	
<p>Jumper CRES1-30 to CRES1-87</p>	<p>Jumper CRES3-30 to CRES3-87</p>
	
<p>Disconnect Wire 0F3 at CRES3-87a</p>	

5. Press and reset the cab E-stop to verify proper operation of relays in the LVCC:
 - a. 0F1 (CRES2-87) has 0V when the E-stop is pressed and 24V when the E-stop is reset.
 - b. 0F2A (CRES4-87) has 0V when the E-stop is pressed and 24V when the E-stop is reset.
 - c. 0F3 (CRES4-87a) has 24v when an E-stop is pressed and 0V when the E-stop is reset.

		<p style="text-align: center;">TA15716-29</p> <p style="text-align: center;">426-0950 (20A)</p>
CRES2-87 (0F1)	CRES4-87 (0F2A)	CRES4 Layout

6. Repeat step 5.a for each of the four ground level E-stops.
7. Press and reset the right rear E-stop to verify proper operation of relays in the Engine box.
 - a. DDEC (MTU)
 - i. 2BA (CR211-87) has 0V when the E-stop is pressed and 24V when reset.
 - b. ADEC (MTU)
 - i. 2AA1 (CR213-30) has 0V when the E-stop is pressed and 24V when reset.
 - c. Cummins
 - i. F01A (CR211-87) has 0V when the E-stop is pressed and 24V when reset.

DDEC CR211-87 (2BA)	ADEC CR211-30 (2ACB)	Cummins CR211-87 (F01A)

8. Remove the jumper at CRES1 installed in step 4.
9. Remove the jumper at CRES3 installed in step 4.
10. Reconnect the 0F3 wire at CRES3-87a disconnected in step 4.
11. Press and reset the 5 E-stops one at a time to verify that the display indicates which E-stop is pressed.

12. Reset the hydraulic reservoir air release valve.

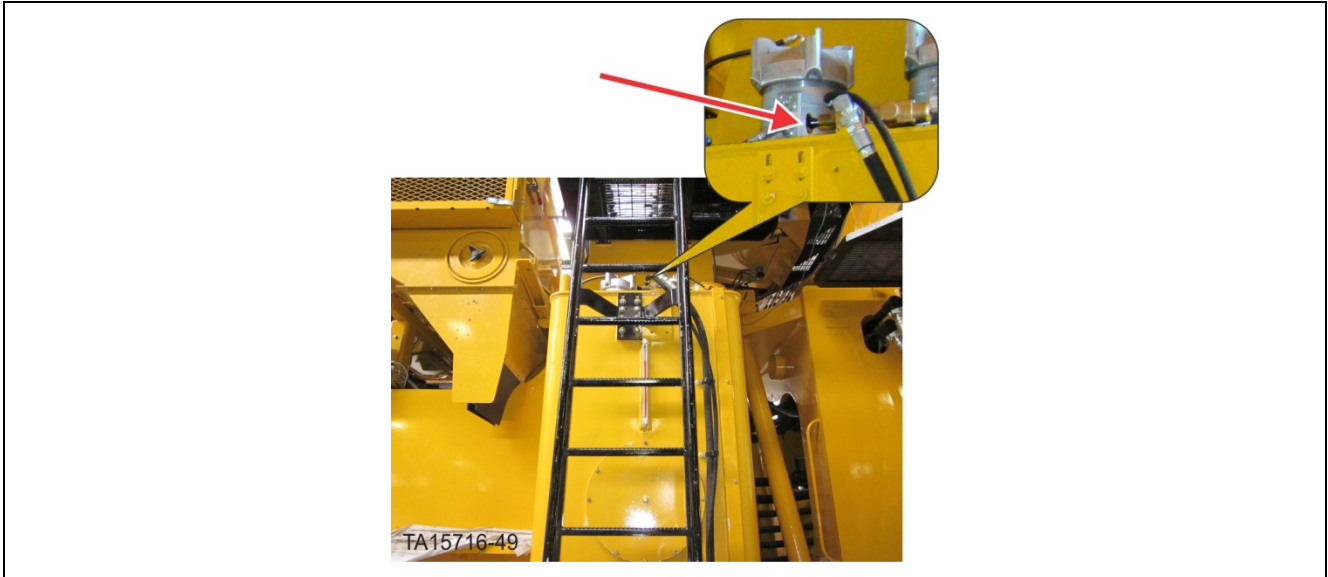
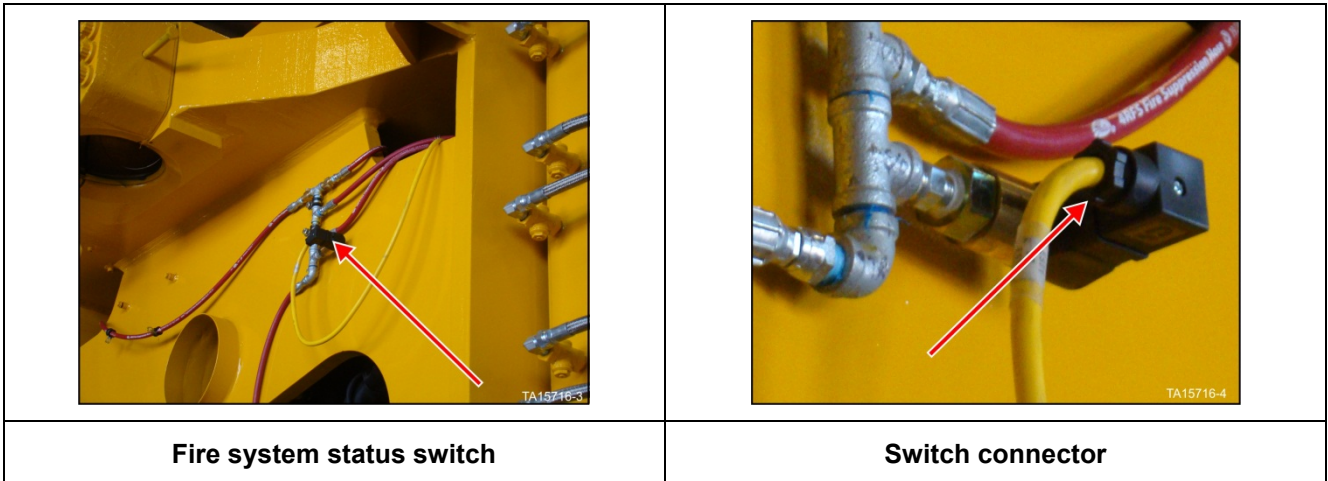

Figure 16. Hydraulic reservoir air release valve

13. Remove the connector from the fire system pressure switch. Jumper pins 1 and 3 together on the connector. Verify that the display indicates a fire system activation and the hydraulic reservoir air release valve activates.



14. Remove the jumper from the fire system pressure switch connector and reconnect it to the pressure switch.

15. Reset the hydraulic reservoir air release valve.

16. Remove starter isolation and engine lockout/tagout.

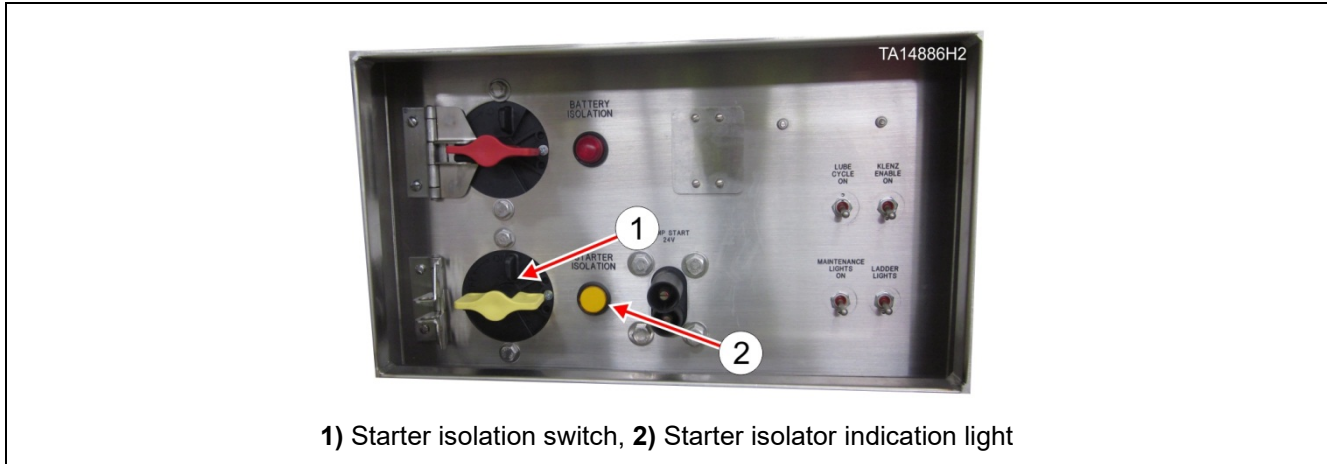

Figure 17. Starter isolation switch

17. Test complete.

18. Follow all lockout tag out rules, local rules, and local regulations to return the machine back to service.

Typical Graphic Symbols for Electrical Diagrams

Device	Class	Type	Symbol
ARC (SURGE) SUPPRESSOR			
BATTERY			
AUDIBLE ALARM			
CIRCUIT BREAKERS	With Thermomagnetic Trip Units	3 Pole	
CONNECTIONS	Connector		
	Conductor or Conductive Path		
	Mechanical		
	Not Connected		
	Connected		
	Ground		
	Chassis or Frame		
CONTACTS	Normally Open		
	Normally Closed		
RELAYS, CONTRACTORS, ETC.			
RECTIFIER, SILICON CONTROLLER (SCR)			
DIODE		Zener Diode	
		LED	
RESISTOR	Fixed		
	Variable		

Device	Class	Type	Symbol
SWITCHES	Limit	Normally Open (N.O.)	
		N.O. Held Closed	
		Normally Closed (N.C.)	
		N.C. Held Open	
	Foot	Normally Open	
		N.O. Closing On Rising Level	
	Liquid Level (Float)	N.C. Opening On Rising Level	
		N.O. Closing On Rising Level	
	Pressure or Vacuum	N.C. Opening On Rising Level	
		N.O. Closing On Rising Level	
Temperature	N.O. Closing On Rising Temperature		
	N.C. Opening On Rising Temperature		
Toggle Maintained	Normally Open		
	Two Position		
FIELD	Interpole		
	Series		
	Shunt		
LIGHTS			
MOTORS, GENERATORS	AC Motor	3 Phase	
	DC Motor		
	AC Generator	3 Phase Wye Conn.	
	Armature With Brushes		

Device	Class	Type	Symbol
OPERATIONAL AMPLIFIER			
OPTOISOLATOR		Photo-Resistor	
		Photo-Transistor	
PUSHBUTTONS	Normally Open		
	Normally Closed		
CAPACITORS	Fixed		
HORN			
THERMAL OVERLOAD ELEMENT			
THERMISTOR / RTD			
TRANSISTORS	Bi Polar	PNP	
		NPN	
FUSE			
POSITION SENSORS			
ROTARY SELECTOR	Non-Bridging Contacts		
SOLENOIDS	General		
TRANSFORMERS	Current (Transductor)		
	General		
	With Magnetic Core		
	*Potential		

NOTE: On elementary diagrams, windings of the same transformer may be shown at different locations.

*With polarity mark () when required. Instantaneous direction of current into one polarity mark corresponds to current out of the other mark.

Ref. TA16030

This Page Intentionally Left Blank